



Overview

The **ECP-103** is a microprocessor-based programmable controller designed to control terminal units such as fan coil units, heat pumps, unit ventilators, and chilled ceilings. This controller uses the LonTalk® communication protocol and is LONMARK certified as a Multi-I/O module.

The ECP-103 supports various input types including resistance, voltage, and digital-based ones. Moreover, it provides digital, floating, pulse width modulation, and proportional control for valves, heating elements, fans, and lighting applications.

This controller works with the EC-Smart-Sensor Series, a line of communicating sensors that can be used for indoor temperature measurement, setpoint adjustment, and occupancy state override. In addition, this controller is Open-to-Wireless® ready, and when paired with the Wireless Receiver, it works with a variety of wireless battery-less sensors and switches.

The ECP-103 can be programmed using either EC-gfxProgram, a state-of-the-art object-oriented graphical programming interface tool, or EC-Program, a user-friendly line-by-line programming tool. Both tools are accessible from any LNS®-based software such as Distech Controls' Lonwatcher 3 or from any multi-protocol platform software that supports LONWORKS devices, such as Distech Controls' EC-Net^{AX}, which is powered by the Niagara^{AX} Framework®.

Applications

- Meets the requirements of the following applications:
 - Fan Coil Units
 - Heat Pump Units
 - Unit Ventilators
 - Chilled Ceilings
- Improves energy efficiency when combined with:
 - Motion detectors to automatically adjust a zone's occupancy mode from standby to occupied when presence is detected
 - CO₂ sensors as part of a demand-controlled ventilation strategy that adjusts the amount of fresh air intake according to the number of building occupants
 - Light switches to control both lighting and a room's HVAC occupancy / standby mode setting
- Works with a wide range of wireless battery-less sensors

Features & Benefits

- Programmable using EC-gfxProgram or EC-Program, which are accessible in both LNS-based and Niagara^{AX}-based software, allowing you to work with your preferred network management platform
- Available with an optional Wireless Receiver that supports up to 14 wireless inputs, letting you create wire-free installations and use various wireless battery-less sensors and switches
- LONMARK Multi-I/O module certified, guaranteeing interoperability with other manufacturers' LONMARK-approved controllers
- Highly accurate universal inputs support thermistors and resistance temperature detectors (RTDs) that range from 100 Ohms to 100 000 Ohms, giving you the freedom of using your preferred or engineer-specified sensors, in addition to any existing ones

ECP-103 Controller



Model	ECP-103
Points	10-Point Controller
Universal inputs	4
Wireless inputs ¹	14
Digital (triac) outputs	4
Universal outputs	2
Product Number (EC-Program)	CDIP-103X-00
Product Number (EC-gfxProgram)	CDIP-103G-00

1. Available when an optional Wireless Receiver is connected to the controller.

Recommended Applications

Model	ECP-103
2 Pipe Fan Coil	■
2 Pipe Fan Coil with Changeover Sensor	■
4 Pipe Fan Coil	■
Heat Pump Unit	■
Unit Ventilator	■
Chilled Ceiling	■

Open-to-Wireless Wireless Receiver – Optional



To reduce the cost of installation, and minimize the impact on existing partition walls, the Wireless Receiver enables an ECP-103 controller to communicate with a line of wireless battery-less room sensors and switches.

Wireless Receiver (315)	- Receiver for EnOcean® 315MHz wireless-enabled sensors and switches
Wireless Receiver (868)	- Receiver for EnOcean 868.3MHz wireless-enabled sensors and switches

Note that controllers have one wireless port to support a single Wireless Receiver.

For more information about the EnOcean technology and Open-to-Wireless, refer to the Open-to-Wireless Solution Guide. For more information about the Wireless Receiver module, refer to the Wireless Receiver Datasheet. These documents can be found on our web site at www.distech-controls.eu.

Supported Platforms



EC-Net^{AX}

EC-Net^{AX} is a web-enabled multi-protocol integration solution powered by the Niagara^{AX} Framework, establishing a fully Internet-enabled, distributed architecture for real-time access, automation and control of devices. EC-Net^{AX}'s open framework creates a common development and management environment for integration of LONWORKS[®], BACnet[®] and other protocols. Regardless of manufacturer and protocol, the EC-Net^{AX} system provides a unified modeling of diverse systems and data, providing one common platform for development, management and enterprise applications.



LONWORKS Network Services (LNS)

LNS[®] is a client-server platform that allows multiple users, running different LNS-compatible applications, to access a common source for directory, installation, management, monitoring and control services for the network system being managed. Distech Controls' Lonwatcher is an example of a LNS-based network management tool that can use Plug-Ins to configure and monitor controllers and devices in the control system.

EC-Net^{AX} Wizards and LNS Plug-Ins

EC-gfxProgram Graphical Programming Tool

Distech Controls' EC-gfxProgram is a programming tool that allows you to quickly create control sequences by "dragging and dropping" block objects and then linking the objects with a simple "click, select and release". Select objects from an extensive library of over 90 commonly used functions as well as create your own custom blocks. With a user-friendly interface and intuitive programming environment, HVAC programming could not be easier. Refer to the EC-gfxProgram datasheet for more information.

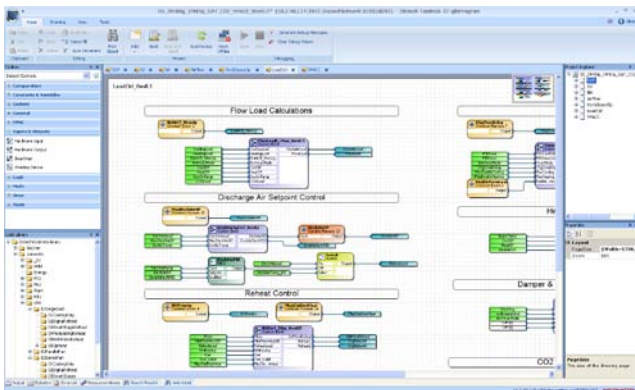

EC-gfxProgram Software features:

- Program both ECP Series LonWorks and ECB Series BACnet controllers with the same tool
- Supplied as freeware – there are no associated licensing costs
- Block-oriented programming
- Live debugging allows user to view code execution, input/output values and to detect errors in real-time
- Extensive block library of the most commonly used functions divided into 11 convenient categories containing over 90 block objects
- A code library for managing your favorite or most commonly used code or code sections
- Backup / Restore function stores the complete code in the controller allowing the retrieval of all programming code features

EC-Program Programming Tool

Distech Controls' EC-Program is unique in the controls industry because it combines a user-friendly GUI (Graphical User Interface) with the power and flexibility of a code editor and compiler. The EC-Program configuration tool uses a special and simplified version of BASIC that has been developed in-house and that is custom made to suit control requirements. Refer to the EC-Program datasheet for more information.

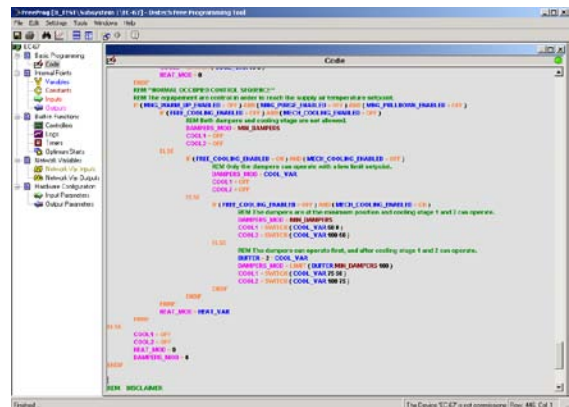

EC-Program Software features:

- Line-by-line programming
- Built-in screen to view and configure internal point values such as variables, constants, etc.
- Uses integers ranging from ± 32767
- 18 NVIs and 18 NVOs; changeable type and length
- 2 NVI Fan-in bindings
 - 1 NVI – High and Low selection
 - 1 NVI – Weighted Average
- 10 PID loops
- 4 NVI Schedules. Changeable type and length. Supported types are: SNVT_tod_event; SNVT_occupancy; and SNVT_hvac_mode
- Programming functions such as Reserved Words (SQRT, SWITCH, LIMIT, etc.)
- Up to 24 trend log objects for a total of 12,000 stored events in the controller

Other Configuration Software

EC-Scheduler Tool

Distech Controls' EC-Scheduler allows users to easily configure a week-based schedule and a special day schedule for holidays. Easily add and remove the special day event into the calendar by a simple click of the mouse!

RTC Configuration Tool

Distech Controls RTC Configuration Tool allows users to manage the time, date and daylight saving time for use with any device on the network.



Please note that though there is an RTC Configuration Tool, there is no actual RTC in the controller. In order for the correct time and date to be maintained within the controller as well as to use schedules, it must be updated automatically (through a network binding) or manually by the user.

Complementary Products

Temperature Sensors

Supported Smart-Sensors (EC-gfxProgram only)



EC-Smart-Sensor-100	Communicating sensor with 2-line LCD, setpoint adjustment, occupancy override, and room temperature display
EC-Smart-Sensor-200	Communicating sensor with 2-line LCD, setpoint adjustment, fan speed control, occupancy override, HVAC mode selection, and room temperature display
EC-Smart-Sensor-FC	Communicating sensor with 2-line LCD, setpoint adjustment, fan speed control, and room temperature display
EC-Smart-Sensor-FC-CF	Communicating sensor with 2-line LCD, setpoint adjustment, fan speed control, room temperature display, and °C/°F toggle button

Allure EC-Sensor

Line of discrete sensors



EC-Sensor	Room temperature sensor with communication jack
EC-Sensor-O	Room temperature sensor with occupancy override button and communication jack
EC-Sensor-S	Room temperature sensor with setpoint adjustment and communication jack
EC-Sensor-SO	Room temperature sensor with setpoint adjustment, occupancy override button, and communication jack
EC-Sensor-SOF	Room temperature sensor with setpoint adjustment, occupancy override button, fan speed selection, and communication jack

Open-to-Wireless Sensors and Switches (requires Wireless Receiver and EC-gfxProgram)

Allure Wireless Battery-less ECW-Sensor

Line of wireless, battery-less sensors. Available in EnOcean 315MHz and 868.3MHz versions.



ECW-Sensor	Room temperature sensor
ECW-Sensor-O	Room temperature sensor with occupancy override button
ECW-Sensor-S	Room temperature sensor with setpoint adjustment
ECW-Sensor-SO	Room temperature sensor with setpoint adjustment and occupancy override button
ECW-Sensor-SOF	Room temperature sensor with setpoint adjustment, occupancy override button, and fan speed selection

Wireless EnOcean Sensors and Switches



41-580	Wireless solar-cell powered motion detector. Available at 868.3MHz.
--------	---



2-channel Light Switch 4-channel Light Switch	2-/4-channel wireless light switches (European models). Available at 315MHz or 868.3MHz.
--	--



PTM265 PTM265D	2-/4-channel wireless light switches (North American models). Available at 315MHz or 868.3MHz.
-------------------	--

For a complete list of the Open-to-Wireless EnOcean sensors and switches that are compatible with the ECP-103, refer to the Open-to-Wireless Solution Guide which can be found on our web site at www.distech-controls.eu.

Other



Terminal Block Cover	Cover designed to conceal the wire terminals. Required to meet local safety regulations in certain jurisdictions.
----------------------	---

For more information on these or other Distech Controls products please refer to our web site at www.distech-controls.eu or contact salesadmin@distech-controls.com.

Controller Dimensions

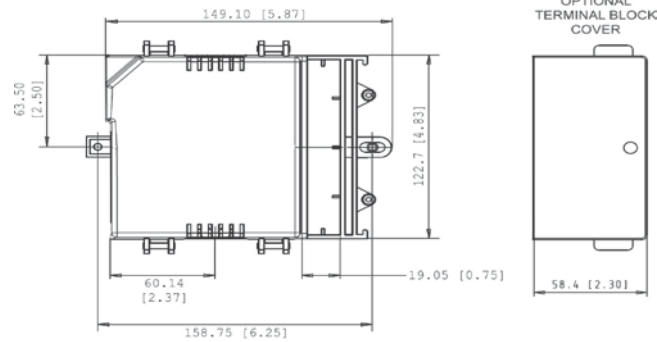

Units Legend: mm [inches]

Product Specifications

Power		Inputs	
Voltage	24VAC; $\pm 15\%$; 50/60Hz; Class 2	Input Types	Universal; software configurable
Protection	3.0A user-replaceable fuse for triac outputs when using the internal power supply	-Voltage	0-10VDC
Typical Consumption	18VA; triac outputs (2 valves @ 4VA) & 2 outputs with 20mA load @ 12VDC	-Current	4-20mA with 249 Ω external resistor (wired in parallel)
Maximum Consumption	70VA - if internal power supply is used	-Digital	Dry contact
Interoperability		-Pulse	Dry contact; 500ms minimum ON/OFF
Communication	LonTalk protocol	-Resistor	
Channel	TP/FT-10; 78Kbps	<i>Thermistor</i>	10K Ω Type 2, 3 (10K Ω @ 25 $^{\circ}$ C; 77 $^{\circ}$ F) Range: -40 $^{\circ}$ C to 150 $^{\circ}$ C; -40 $^{\circ}$ F to 302 $^{\circ}$ F
LONMARK Interoperability Guidelines	Version 3.4	<i>Platinum</i>	Pt1000 (1K Ω @ 0 $^{\circ}$ C; 32 $^{\circ}$ F) Range: -40 $^{\circ}$ C to 150 $^{\circ}$ C; -40 $^{\circ}$ F to 302 $^{\circ}$ F Pt100 (100 Ω @ 0 $^{\circ}$ C; 32 $^{\circ}$ F) Range: -40 $^{\circ}$ C to 135 $^{\circ}$ C; -40 $^{\circ}$ F to 275 $^{\circ}$ F
Device Class	Multi I/O module	<i>Nickel</i>	RTD Ni1000 (1K Ω @ 0 $^{\circ}$ C; 32 $^{\circ}$ F) Range: -40 $^{\circ}$ C to 150 $^{\circ}$ C; -40 $^{\circ}$ F to 302 $^{\circ}$ F
LONMARK Functional Profile		<i>Potentiometer</i>	Translation table configurable on several points
- Input objects	Open-Loop Sensor #1	Input Resolution	16-bit analog / digital converter
- Output objects	Open-Loop Actuator #3	Outputs	
Hardware		Digital	24 VAC Triac, digital (on/off), PWM, or floating ¹ ; software configurable
Processor	Neuron [®] 3150; 8 bits; 10MHZ		- 0.5A continuous
Memory	Non-volatile Flash 64K (APB applications) Non-volatile Flash 128K (storage)	Universal	- 1.0A @ 15% duty cycle for a 10-minute period
Environmental			- PWM control: adjustable period from 2 seconds to 15 minutes
Operating Temperature	0 $^{\circ}$ C to 50 $^{\circ}$ C; 32 $^{\circ}$ F to 122 $^{\circ}$ F		- Floating control: requires two consecutive outputs ¹
Storage Temperature	-20 $^{\circ}$ C to 50 $^{\circ}$ C; -4 $^{\circ}$ F to 122 $^{\circ}$ F		- Min pulse on/off: 500msec.
Relative Humidity	0 to 90% Non-condensing		- Adjustable drive time period
Enclosure			External or internal power supply (jumper selectable)
Material	FR/ABS		0-10VDC, digital 0-12VDC (on/off), floating ¹ or PWM
Color	Black & blue casing & grey connectors		- PWM control: adjustable period from 2 seconds to 15 minutes
Dimensions (with Screws)	4.8" x 5.9" x 2.5" (122.7mm x 149.1mm x 63.0mm)		- Floating control: requires two consecutive outputs ¹
Shipping Weight	0.92lbs (0.42kg)		- Min pulse on/off: 500msec.
Wireless Receiver²			- Adjustable drive time period
Communication	EnOcean wireless standard		- 20mA max. @ 12VDC
Number of wireless inputs ³	14		- Minimum load resistance 600 Ω
Supported Wireless Receivers	Wireless Receiver (315) Wireless Receiver (868)		10-bit digital / analog converter
Cable	Telephone cord	Output Resolution	
- Connector	4P4C modular jack		
- Length	6.5ft; 2m		
EC-Smart-Sensors⁴			
Models Supported	EC-Smart-Sensor-100, EC-Smart-Sensor-200, EC-Smart-Sensor-FC, EC-Smart-Sensor-FC-CF		
Power & Communication	2-wire		
Number of sensors supported	1		

Product Specifications (continued)

Electromagnetic Compatibility

CE -Emission	EN61000-6-3: 2007; Generic standards for residential, commercial and light-industrial environments
-Immunity	EN61000-6-1: 2007; Generic standards for residential, commercial and light-industrial environments
FCC	This device complies with FCC rules part 15, subpart B, class B



Agency Approvals

UL Listed (CDN & US) Material ⁵	UL916 Energy management equipment UL94-5VA
--	---





Communication Protocols and Standards



enocean®



1. Available only when controller is programmed with EC-gfxProgram.
2. Available when an optional external Wireless Receiver is connected to the controller. Refer to the Open-to-Wireless Solution Guide for a list of supported EnOcean wireless modules.
3. Some wireless sensors may use more than one wireless input from the controller.
4. An EC-Smart-Sensor and Wireless Receiver cannot be used at the same time.
5. All materials and manufacturing processes comply with the RoHS directive  and are marked according to the Waste Electrical and Electronic Equipment (WEEE) directive .

Product Warranty & Total Quality Commitment

All Distech Controls product lines are built to meet rigorous quality standards and carry a two-year warranty. Distech Controls is an ISO 9001 registered company.

Functional Profile (with EC-gfxProgram)

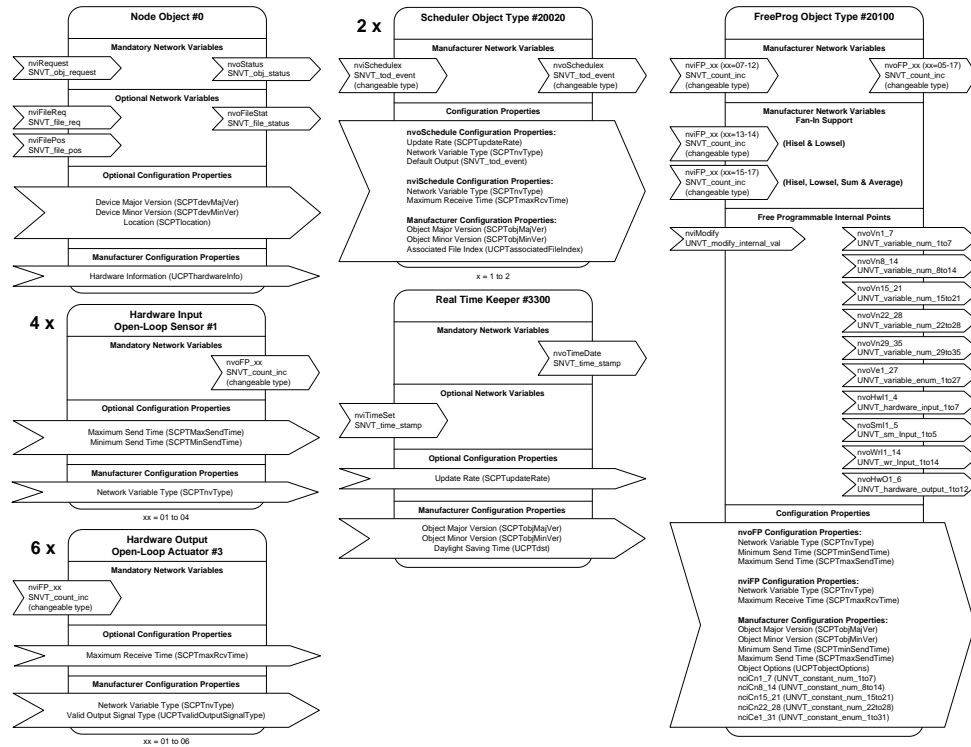

Functional Profile (with EC-Program)

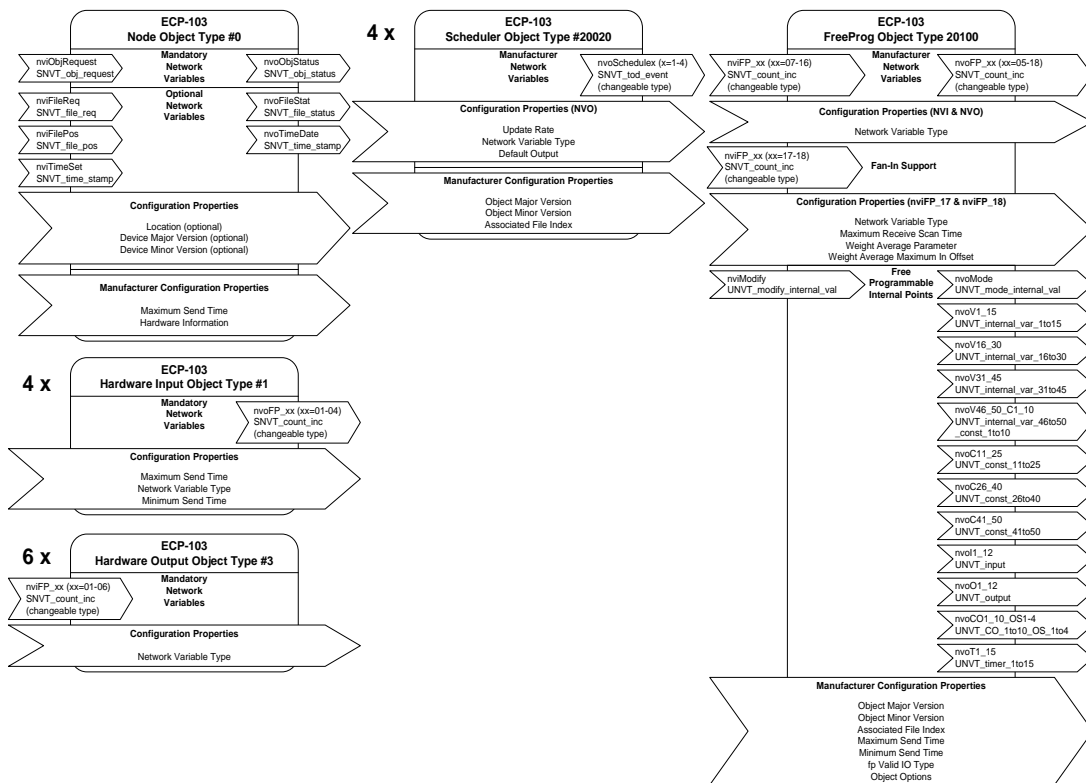

Specifications subject to change without notice.

Distech Controls, the Distech Controls logo, and Open-To-Wireless are trademarks of Distech Controls Inc.; LONWORKS, LONMARK, LonTalk, and LNS are registered trademarks of Echelon Corporation; Niagara^{AX} Framework is a registered trademark of Tridium, Inc.; BACnet is a registered trademark of ASHRAE; EnOcean is a registered trademark of EnOcean GmbH. All other trademarks are property of their respective owners.



05DI-DSEP103-10E

ECP-103

www.distech-controls.eu

717